



INSTALLATION AND CONNECTION

Installation height	Children 4-10 - 33 in (85 cm)
Men - 49 in (125 cm)	Children 10-15 - 39 in (100 cm)
Women - 43 in (110 cm)	Handicapped - 37 in (95 cm)

Installation

Remove the cover. Mark the 4 mountings holes and the supply cable outlet on the wall. Install supply cable then mount the unit on the wall.

Connection

Rear power cable connection with cable-grip. Removable front panel for installation and wiring through the front.

Note Cover secured with tamper proof screws.

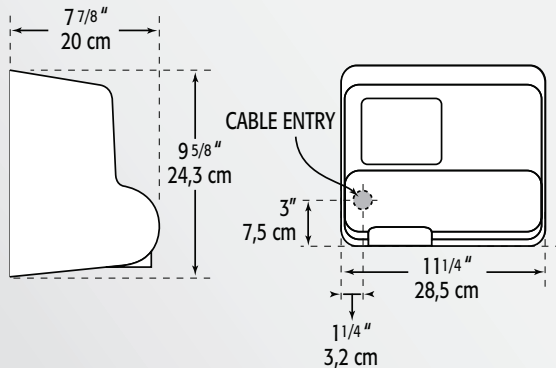

Jetstream

39
convectair.com



HEATING ELEMENT

Total capacity 2400 W (120V), 2063 W (208V) and 2750 W (240V)

Blower Element mounted downstream from turbine for rapid heating, maximum efficiency and minimum heat loss.

TEMPERATURE CONTROL

Electronic power card control for a better reliability.

Motor Powerful 1/3 HP universal motor (250 W / 188 W) for superior performance and long life.

Turbine High-efficiency turbine for reduced drying time. Rotation speed : 7500 rpm.

Timed-uvfrated electronic sensor for automatic start and stop, total hygiene and maximum economy.

Output temperature 140°F (60°C) at a room temperature of 72°F (22°C).

Airflow 195 cfm (5,5 m3 / min)

CABINET

Cover Aluminum die cast with heavy duty powder coated polyester finish.

Interior assembly Die cast monoblock housing designed for improved air flow and enhanced performance.

Weight 12 1/2 lb (5.7 kg)

Color BB = White (other colors available on request).

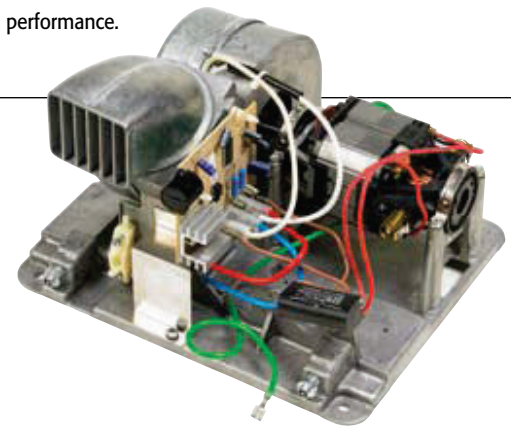

MODEL	Catalog No.	Color	Voltage (V)	Nominal Power (W)	AMPS (A)	Heating Element (W)
JETSTREAM	2517-C24	BB	120	2 400	20,0	2 150
	2517-C27	BB	208 -240	2063 - 2750	10,0 - 11,5	1875 - 2500

For guaranteed, dependable operation, we recommend that all units be installed by a licensed electrical contractor. Consult **convectair.com** to find the most recent installation instructions for our heaters.

